

# ECON FP SERIES SPECIFICATIONS

**STENNER PUMPS®**

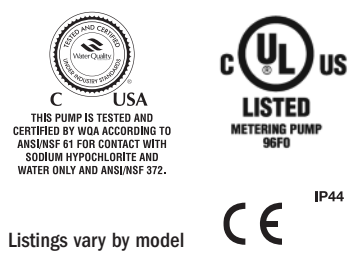

**Shipping Weight** 4 lbs (1.7 kg)

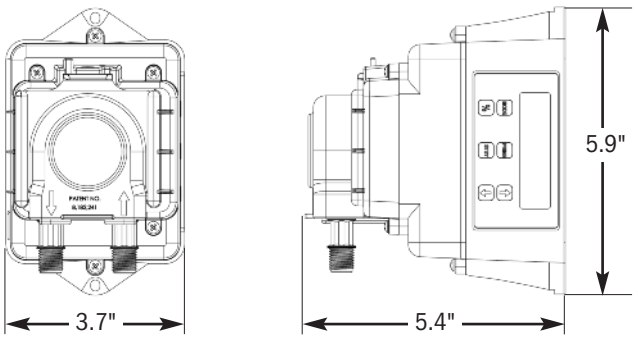

## SPECIFICATIONS

- Flow Rate Output Control** Six button control panel with LCD display
- Reproducibility** ±2%
- Maximum Working Pressure** 80 psi (5.5 bar)
- Maximum Operating Temperature** 104°F (40°C)
- Maximum Suction Lift** 25 ft (7.6 m) vertical lift, based on water
- Motor Type** 240VDC, brushless
- Shaft RPM (average maximum)** 60
- Duty Cycle** Continuous
- Motor Voltage** 120V 60Hz (0.25A), 230V 60Hz (0.17A), 230V 50Hz (10W), 24VDC (0.85A)
- Power Cord Type** 120V 60Hz, 230V 60Hz: SJTOW, 240V 50Hz: H05RN-F, 24VDC pigtail
- Power Cord Plug End** 120V 60Hz NEMA 5-15P, 230V 60Hz NEMA 6-15P, 230V 50Hz CEE7/7, 24VDC pigtail
- Power Cord Length** 6 ft (1.8 m), 10 ft (3.05 m) or 24VDC Pigtail 1 ft (30.5 cm)
- Classification** Indoor/outdoor

## MATERIALS OF CONSTRUCTION

- All Housings** Polycarbonate
- Pump Tube & Check Valve Duckbill** Santoprene™ (FDA approved)
- Pump Head Rollers** Polyethylene
- Suction/Discharge Tubing, Ferrules** Polyethylene (FDA approved)
- Tube and Injection Fittings** PVC or Polypropylene (both NSF listed)
- Connecting Nuts** PVC (NSF listed)
- Suction Line Strainer and Cap** PVC or Polypropylene (both NSF listed); ceramic weight
- All Fasteners** Stainless steel

## ACCESSORIES

- 3** Connecting nuts 1/4"
- 3** Ferrules 1/4" or 6 mm *Europe*
- 1** Duckbill check valve
- 1** Weighted suction line strainer 1/4" or 6 mm *Europe*
- 1** 20' Roll suction/discharge tubing 1/4" white or UV black OR 6 mm White *Europe*
- 1** Additional pump tube
- 1** Manual

\* Santoprene® is a trademark of Exxon Mobil Corporation.

## FEATURES

- Activated by a softener valve, water meter, flow switch or other flow activated equipment
- Accepts dry contact or 12-24 VAC/VDC signal
- Enclosed housing
- Self-priming, does not lose prime or vapor lock
- Pumps off-gassing solutions and can run dry
- 3-point roller design assists with anti-siphon
- Tube replacement without tools
- Output reproducibility

## FLOW RATE OUTPUT CHART

**80 psi (5.5 bar) maximum**

Item Number Prefix	Pump Tube	Roller Assembly	Turndown Ratio	Gallons per Day	Gallons per Hour	Ounces per Hour	Ounces per Minute	Liters per Day	Liters per Hour	Milliliters per Hour	Milliliters per Minute
E10PLM	M	White	10:1	0.49	0.02	2.6	0.04	1.84	0.08	76.7	1.3
E10PHM	M	White	10:1	0.83	0.03	4.4	0.07	3.14	0.13	130.8	2.2
E20PHM	M	White	10:1	1.41	0.06	7.5	0.13	5.36	0.22	223.2	3.7
E20PHF	F	White	10:1	4.5	0.19	24.0	0.40	17.01	0.71	708.8	11.8
E20PHG	G	Black	10:1	16.0	0.67	85.3	1.42	60.48	2.52	2520.0	42.0
E20PHH	H	Black	10:1	30.0	1.25	160.0	2.67	113.40	4.73	4725.0	78.8

Approximate Maximum Output @ 50/60Hz

**NOTICE:** The information within this chart is solely intended for use as a guide. The output data is an approximation based on pumping water under a controlled testing environment. Many variables can affect the output of the pump. Stenner Pump Company recommends that all metering pumps undergo field calibration by means of analytical testing to confirm their outputs.